

LPH250 & LPH400 (ELECTRIC) Ladder Hoist

Instruction and safety information

Read before operating the ladder hoist

Index

Warning	2
Introduction	3
Assembling of platform	4
Mounting the platform to the ladder	4
Erecting the ladder hoist	5
Mounting the power unit	6
Operation	7
Maintenance	8
Brake adjustment	9
Drawing : Brake & clutch	10
Clutch adjustment	11
Clutch-brake adjustment	11
Parts list	12
Drawing : Power unit	13
Drawing : LPH250	14

88 Signet Drive
Weston, ON M9L 1T3
Tel: (416) 744-2050
Fax: (416) 744-4247

• Pickering, ON	• Weston (Weston Rd.), ON	• Oakville, ON	• Edmonton, AB
• Toronto (Bloor St.), ON	• Weston (Signet Dr.), ON	• Hamilton, ON	• Calgary, AB
• Toronto (Wade Ave.), ON	• Barrie, ON	• London, ON	• Winnipeg, MB
			• Bensenville (Chicago), IL

WARNING

- Do not erect the ladder hoist near overhead cables, electricity power lines or wires.
- Erect ladder hoist on firm and level ground.
- Tighten all bolts and nuts securely or ladder hoist failure will occur under load and may cause damage or injury.
- Do not ride on hoist platform.
- Do not climb on hoist ladder. Ladder is for hoisting material only.
- Do not remove safety cover when motor is running.
- Do not jam on brake or apply excessive force on brake handle. Brake band may break and serious damage or injury may occur.
- Lower the platform to the bottom home position when the hoist is not in use or when servicing.
- Belt must be installed properly under the belt guard.
- Read and follow the instructions and warnings.
- Do not use this equipment when it is damp. It can result in serious electric shock.

Warning labels have been included on the equipment. If the warning labels wear off, please request for new ones.

Misuse of the ladder hoist may result in injury or damage. SPAR-Marathon provides instructions for its safe use and relies on the purchaser to ensure that these instructions are given to the personnel who will actually be using the equipment.

It is the responsibility of the purchaser to ensure that the personnel operating the ladder hoist is trained in the proper operating procedures and all safety regulations.

The employer shall instruct each employee in the recognition and avoidance of unsafe conditions and the regulations applicable to work environment to control or eliminate any hazards or other exposure to illness or injury.

Regulations governing the use, selection and maintenance of personal protective and lifesaving apparatus regulations must be followed.

SPAR-Marathon ladder hoist is designed and manufactured for hoisting material only. Any other use of this equipment will void any warranty or responsibility, expressed or implied, on the part of the manufacturer.

Ladder hoist should be operated by experienced personnel only. It is a good idea to barricade the hoisting area and to keep unauthorized persons away from it.

Introduction

SPAR-Marathon LPH ladder hoist is designed for easy and trouble free operation. It is designed for hoisting roofing materials to the roof up to 44 feet, easily and effectively. All sheaves, wheels and pulleys use sealed ball bearings to reduce maintenance and provide longer ladder hoist life. All moving parts are covered with safety covers for maximum personal safety.

SPAR-Marathon LPH ladder hoist standard package comes with one 16-foot ladder with shoes, one 8-foot section and one 4-foot section. Ladders of 16 feet, 20 feet, 24 feet and 28 feet can be assembled with these sections. (Optional ladder section is available to extend the ladder hoist to 44 feet. Ladder hoists longer than 28 feet require the use of ladder supports.)

SPAR-Marathon LPH series ladder hoist features include:

LPH250

- Heavy duty aluminium ladder; 17½" wide with 4" rails
- One handle brake operation
- One handle belt clutch operation
- Self-locking brake with non-asbestos brake pad and aluminium brake drum
- Sealed ball bearing wheels, pulleys and sheaves
- Steel safety cover
- Heavy duty frame with 1.5 hp electric motor
- LPH250 platform
- 200 lbs hoisting capacity
- Maximum hoist speed various to 240 feet per minute
(based on 130 feet, 5/32 diameter aircraft cable)

LPH400

- Heavy duty aluminium ladder; 24" wide with 4" rails
- Reinforced rungs for power unit mounting
- One handle brake operation
- One handle belt clutch operation
- Self-locking brake with non-asbestos brake pad and aluminium brake drum
- Sealed ball bearing wheels, pulleys and sheaves
- Steel safety cover
- Heavy duty frame with 1.5 hp electric motor
- LPH400 platform

- 400 lbs hoisting capacity
- Maximum hoist speed various to 120 feet per minute
(based on 130 feet, 5/32 diameter aircraft cable, double line setting)

Specifications are subject to change without notice.

Assembling of platform

⚠ Warning Tighten all bolts and nuts securely or ladder hoist failure will occur under load and may cause damage or injury.

LPH250

Fasten the two brace bars with bolts and nuts provided on the horizontal platform and top hole at the vertical platform.

LPH400

Fasten the two brace bars with bolts and nuts provided at the inner hole on the horizontal platform and hole at the vertical platform. Optional load retaining bars can be bolted to the outer edge of the horizontal platform.

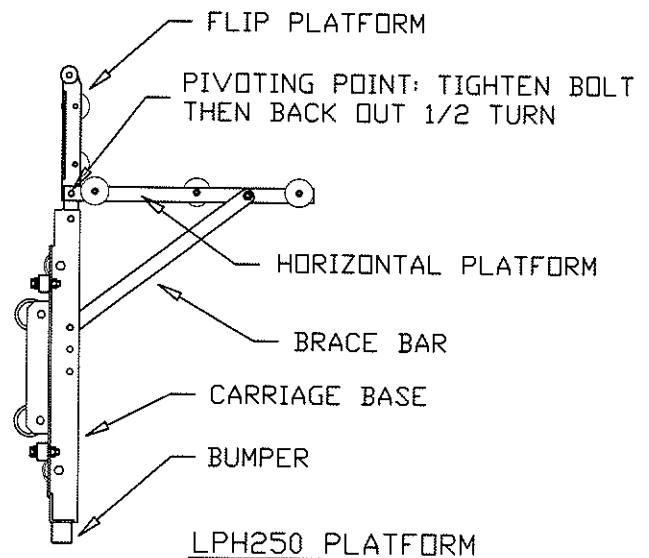

Mounting the platform to the ladder

⚠ Warning Tighten all bolts and nuts securely or ladder hoist failure will occur under load and may cause damage or injury.

Before assembling the ladder hoist, determine a suitable length so that the ladder top is project 2 to 2 1/2 feet above the roofline. Optional extension ladder sections can be installed to extend the ladder to 44 feet. Ladder support must be used if length of ladder is over 28 feet.

Assemble the ladder as follows:

- Lay the 16-foot ladder flat on the level ground.
- Loosen the top cover pulley assembly.

- Slide the two connecting plates into both I-beams on the inside slot of the ladder.
- Slide the extension ladder section onto the connecting plates. Make sure the two ladder sections align and touching.
- Tighten the connection plates securely on the ladder with bolts and nuts. Bolt heads on outside and nuts on inside.
- Slide the top cover pulley assembly to the top of ladder and tighten with bolts and nuts securely. Bolt heads on outside and nuts on inside.
(For LPH 400, springs stopper should be close to the platform side)
- Slide the platform onto the I-beam from the shoes side of ladder.
- With the platform fully inside the ladder, tie the platform with a rope on one of the rungs. This will avoid the platform from sliding off the ladder when erecting the ladder.

Erecting the ladder hoist

 **Warning** Do not erect the ladder hoist near overhead cables, electricity power lines or wires.

Extreme care must be taken to erect the ladder assembly due to its long length and heavy weight.

Make sure the ladder shoes sit firmly on level ground to prevent the ladder from slipping and uneven loading on the I-beam of the ladder. Failure to do so may cause damage to equipment or personal injury.

Two methods are suggested for erecting the ladder assembly.

Method 1

Lay the ladder assembly on the ground with the platform on top and parallel to the wall of the building where the ladder will be resting on.

One person on top of the roof lowers a rope to the ground. A person on the ground ties the rope end to the top cover pulley assembly. While the person on the roof pulls against the rope to raise the ladder, the person on the ground braces the feet of the ladder to avoid the ladder from slipping.

Another person on the ground can help raise the ladder by pushing the ladder rails or rungs hand over hand from ladder top towards the bottom side.

Carefully rotate the ladder assembly 90 degrees when ladder is in a vertical position. The platform should be facing outside. Move the ladder feet away from building wall equal to 1/4 to 1/3 of the building height. Be sure to add the length equal to the overhang if applicable. (15 to 20 degrees to vertical)

Tie the ladder securely to the roof with a rope fastened to the rung of the ladder. Do not tie on the rail.

Method 2

Lay the ladder assembly on the ground with the platform on top and perpendicular to the building with the ladder shoes against the wall.

One person on top of the roof lowers a rope to the ground. A person on the ground ties the rope end to the top cover pulley assembly. While the person on the roof pulls against the rope to raise the ladder, the person on the ground pushes the ladder rails or rungs hand over hand from ladder top towards the bottom side.

Carefully rotate the ladder assembly 180 degrees when ladder is in a vertical position. The platform should be facing outside. Move the ladder feet away from the building wall equal to 1/4 to 1/3 of the building height. Be sure to add the length equal to the overhang if applicable. (15 to 20 degrees to vertical)

Tie the ladder securely to the roof with a rope fastened to the rung of the ladder. Do not tie on the rail.

Mounting the power unit

⚠ Warning Make sure the cable runs straight up on the underside, past through the top pulley and straight down on the platform side to the platform hook without going through any rung. (going up again on the platform side to the hook on the top cover pulley assembly on LPH400 model)
Cable will cut through the rungs if not install properly and will cause damage to equipment or personal injury.

- Mount the power unit on the 3rd and 5th rungs on the underside (closer to the wall) of the ladder. (For LPH400: position the power unit to the centre of the rung). Rotate the top locking handle clockwise to tighten the clamp. Lock the handle to the frame with the lock pin through the two holes.

- Mount the clutch and brake handles to the side of the power unit and fasten with the lock pins. Short handle is for the brake.
- One person on the roof lowers a rope and a person on the ground ties the rope to the cable end.
- With the brake release, the person on the roof pulls the cable to the roof and threads it through the sheave on the top cover pulley assembly from underside to the platform side.
- Lower the cable and fasten the cable end to the hook at the back of the platform. Make sure the cable is on the platform side and do not go through any rung. (For LPH400 model: the LPH400 requires 2 parts of load lines. After lowering the cable to the ground, thread it through the sheave on the platform from the left side to the right side (standing on platform side). Pull the cable back to the roof and fasten it to the hook on the top cover assembly.
- Remove the tie rope that is holding the platform onto the ladder and carefully lower the platform to the ground.
- Release brake and rotate the cable drum by hand to take up the loose cable.

Operation

 Warning This unit is installed with 1.5 hp electric motor. Refer manufacturer instructions for operation and maintenance of the motor. Do not operate before reading and understanding the instructions.

Do not remove safety covers when motor is running.

Lower the platform to the bottom home position when the hoist is not in use or when servicing. Do not leave the platform in any other position on the ladder. Sudden release of brake may cause the platform to roll down and will cause damage to equipment or injury to personnel.

Do not jam on brake or apply excessive force on brake handle. Brake band may break and serious damage or injury may occur.

Check the hoist condition each time before using the equipment. Repair or replace components if they are damaged or in bad condition.

Do not operate the ladder hoist if the brake is wet. Follow procedure outlined in maintenance section.

Raising the platform and load

To raise the platform, switch on the motor . Engage the belt clutch by raising the clutch handle. The platform will roll up the rail. Use slower speed when the platform nearly reaches the top. Releasing the clutch handle will engage the brake automatically and hold the platform in desired position.

Lowering the platform and load

To lower the platform, raise the brake handle slowly. The platform will roll down the rail. Lower the platform slowly and always keep control of the lowering speed. Use slower speed when the platform is near the bottom home position to avoid platform from ramming to the ground, which may cause equipment damage or personal injury.

Maintenance

Sealed ball bearings are used in all the wheels, pulleys and sheaves. It is not necessary to grease these components.

Grease the pivot point at the flap platform occasionally.

Always keep the brake assembly dry, clean and avoid grease or oil contamination.

If the brake is wet, do not operate the ladder hoist for hoisting material. A wet brake is difficult to control and the platform will slip under load. Dry the brake by running the platform without load up and down the hoist a few times until the brake functions properly. Keep hand on the brake handle and apply force to assist braking if necessary. (Normally, releasing the brake handle will stop the platform.) Avoid hoisting heavy loads on the platform the first few hoists when back in operation. Always keep hand on the brake handle and apply force to assist braking if necessary.

If oil or grease is found on the brake assembly, use grease or brake cleaner to clean the brake. Follow the cleaner instructions to avoid damage to the brake pad.

If brake band has to be removed for any reason, mark the orientation and install it back to the hoist with same orientation as before removing.

Replace brake band if it is worn out or damaged.

For motor maintenance, refer to the motor instructions manual.

Brake adjustment

⚠ Warning Do not over tighten the spring tension, hoist performance will be adversely affected and brake will wear out faster.

Note: Before adjusting the spring tension, make sure the brake slipping is not due to oil or grease contamination. If oil or grease is found on brake drum or brake band, follow cleaning procedure outlined in maintenance section.

The four bolts on the brake band lever should not be fully tight. Tighten these bolt than back off 1/2 turn so that the components can pivot.

The brake initial pressure is factory preset to give optimum performance. However, brake adjustment is necessary after the brake wears out or if the platform starts drifting down the rail with load.

If platform drifts occurs, lower the platform and load to the bottom home position and switch off the motor. Tighten the nut #1 below the spring two turns. Check if the platform drifts. If the platform still drifts, tighten the nut two turns at a time until the brake holds the platform.

If the brake band has to be removed for service. Make sure to put it back in its original orientation. Adjust the spring initial tension by turning the nut #1 so that the washer is just touching the spring, then turn the nut 12 turns clockwise (1/2 inches) from no tension on spring. If the platform still drifts, tighten the nut two turns at a time until the brake holds the platform.

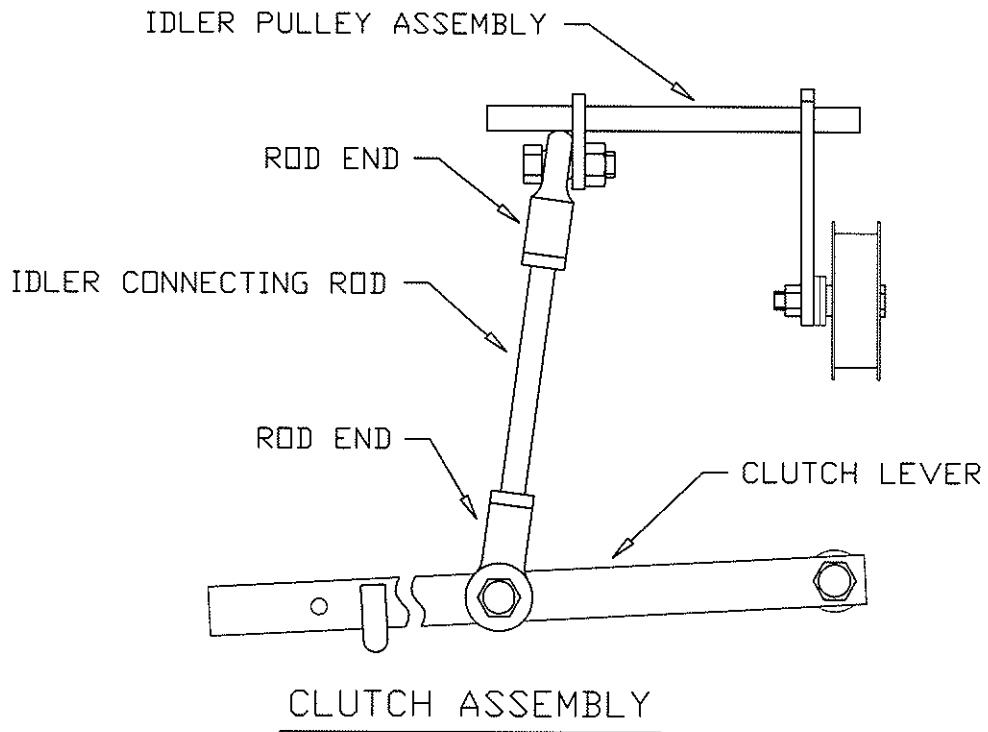
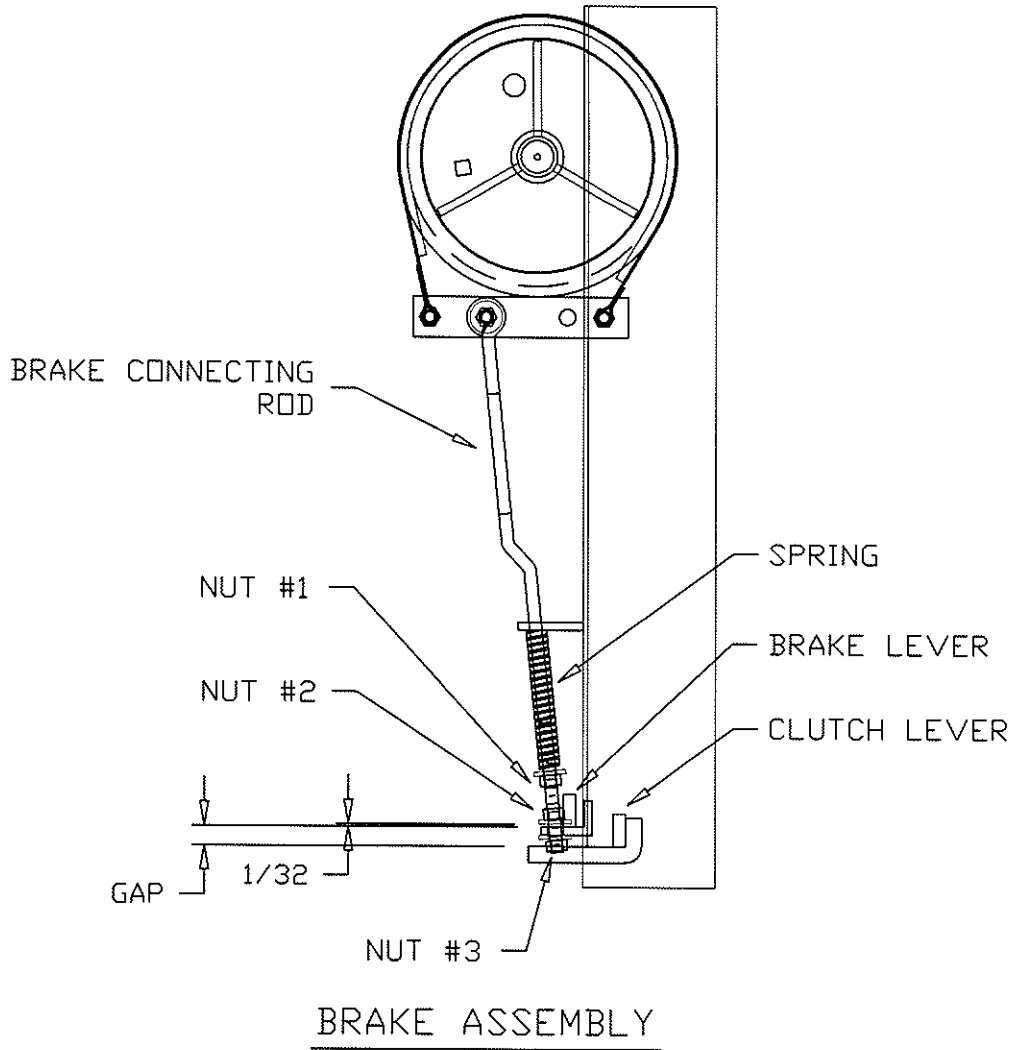

Clutch adjustment

⚠ Warning Do not adjust the belt too tight or the platform will not come down after it goes up the ladder.

Loosen the bolt holding the top rod end on the idler pulley assembly. Rotate the rod end out to tighten the belt and rotate the rod end in to loosen the belt. Re-connect the rod end and check the belt tightness by moving the belt at the bottom of the engine sheave. The belt should have 1/8" to 3/16" up and down movement. Tighten the bolt and nut after adjustment.

Clutch-brake adjustment

Lifting the clutch handle will release the brake before the clutch engages. The optimum position (gap between brake and clutch levers) is factory adjusted before shipping. If motor stalls or the platform falls when clutch handle is lifted, the clutch-brake setting needs adjustment.

In case of motor stalls, loosen the nut #3 two turns down on the brake connecting rod. Then rotate the nut #2 two turns down. This will lower the brake lever so that the brake will release earlier when the clutch handle is being lifted. Once the optimum position is found, turn the nut #3 so that there is a 1/32" gap between the nut # 2 and the brake lever.

In the case of platform fall, rotate the nut #2 two turns up on the brake connecting rod. Then rotate the nut #3 two turns up. This will raise the brake lever so that the brake will release later when the clutch handle is being lifted. Once the optimum position is found, turn the nut #3 so that there is a 1/32" gap between the nut # 2 and the brake lever.

PARTS LIST - LPH250

DESCRIPTION	PART #	QTY
BRACE BAR	LPH2-N37	2
BUMPER	LPH2-N32	2
CARRIAGE BASE	LPH2-NA2	1
LARGE CARRIAGE WHEEL (NYLON)	LPH2-N18	8
CONVEYOR WHEEL	LPH2-27	12
SMALL CARRIAGE WHEEL (NYLON)	LPH2-N39	6
FLIP PLATFORM	LPH2-NA4	1
HOOK	LPH2-13	1
HORIZONTAL PLATFORM	LPH2-NA3	1
LADDER 16FT (OPTIONAL)	LPH2-204	1
LADDER 16FT W/ FEET	LPH2-175	1
LADDER 4FT	LPH2-195	1
LADDER 8FT	LPH2-194	1
SPLICE PLATE	LPH2-174	2
TOP COVER	LPH2-NA5	1
TOP PULLEY	LPH2-N45	1
TOP COVER SPRING	LPH2-N11	4

PARTS LIST - LPH400

DESCRIPTION	PART #	QTY
BRACE BAR	LPH4-40	2
BUMPER	LPH4-20	2
CARRIAGE BASE	LPH4-A2	1
LARGE CARRIAGE WHEEL	LPH2-14	6
CONVEYOR WHEEL	LPH2-27	16
SMALL CARRIAGE WHEEL(NYLON)	LPH2-N39	6
FLIP PLATFORM	LPH4-A4	1
BOTTOM PULLEY	LPH4-23	1
HORIZONTAL PLATFORM	LPH4-A3	1
LADDER 16FT (OPTIONAL)	LPH4-204	1
LADDER 16FT W/ FEET	LPH4-175	1
LADDER 4FT	LPH4-195	1
LADDER 8FT	LPH4-194	1
SPLICE PLATE	LPH2-174	2
TOP COVER	LPH4-A5	1
TOP COVER SPRING	LPH2-N11	4
TOP PULLEY	LPH4-23	1
TOP HOOK	LPH2-13	1

POWER UNIT FOR LPH250 AND LPH400

DESCRIPTION	PART #	QTY
BLOCK BEARING 1" BORE	LPH2-176	2
CABLE DRUM BELT	LPH2-E53	1
BELT COVER	LPH2-A12	1
BRAKE BAND	LPH2-1389	1
BRAKE BAND LEVER	LPH2-140	1
BRAKE CONNECTING ROD	LPH2-141	1
BRAKE COVER	LPH2-170	1
BRAKE HANDLE	LPH2-171	1
BRAKE LEVER	LPH2-1423	1
AIRCRAFT CABLE	LPH2-184	1
CABLE DRUM	LPH2-A7	1
CLUTCH HANDLE	LPH2-172	1
CLUTCH LEVER	LPH2-107	1
FRAME	LPH2-A6	1
FRAME MOUNTING PLATE	LPH2-83	1
MOTOR MOUNTING PLATE	LPH2-E10	1
ELECTRIC MOTOR 1.5 HP	LPH2-E35	1

DESCRIPTION	PART #	QTY
HANDLE GRIP	LPH2-173	2
IDLER ASSEMBLY	LPH2-A8	1
IDLER CONNECTING ROD	LPH2-106	1
IDLER PULLEY	LPH2-E54	1
LOCK	LPH2-A9	1
LOCK CONNECTING BAR	LPH2-123	2
LOCK HANDLE	LPH2A10	1
LOCK HANDLE LOCK PIN	LPH2-135	1
ROD END	LPH2-105	2
SHEAVE BK25 X 5/8 BORE	LPH2-E36	1
SHEAVE 4.25OD X 3/4 BORE	LPH2-E32	1
SHEAVE 8.75OD X 3/4 BORE	LPH2-E34	1
SPRING	LPH2-154	1
SHAFT DIA 3/4	LPH2-E30	1
BLOCK BEARING 3/4 BORE	LPH2-E33	2
MOTOR BELT	LPH2-E37	1
ON/OFF SWITCH	LPH2-E42	1

POWER UNIT FOR LPH 250/LPH400

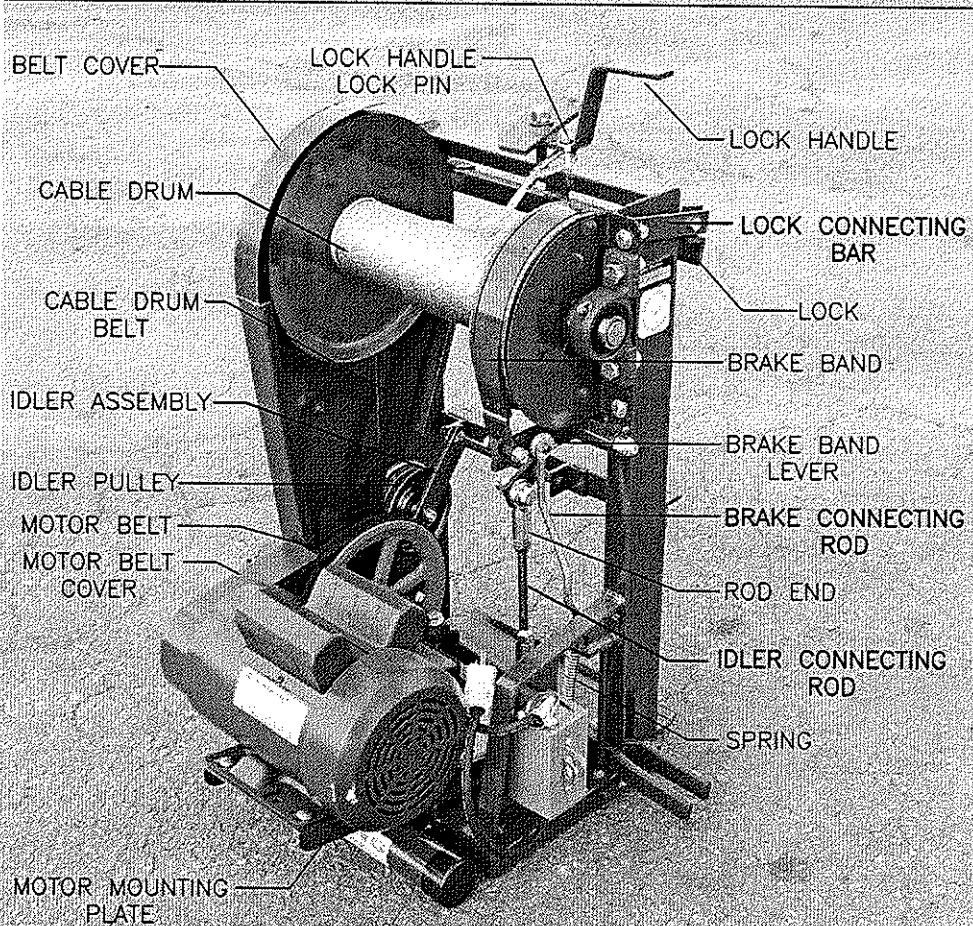
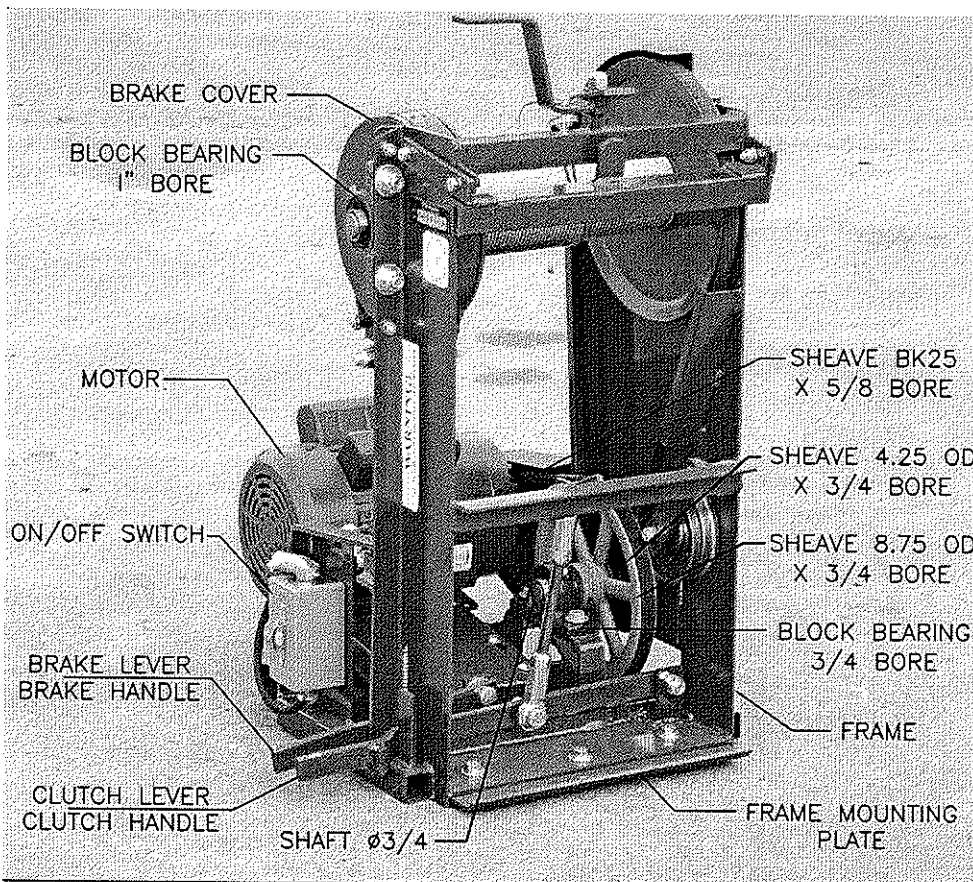

LADDER HOIST LPH250

